

**Scanning the avalanche track for transmitters and locating each signal quickly and exactly** are the decisive advantages of the ORTOVOX avalanche transceiver S1. An immediate search with an avalanche transceiver and a rescue using avalanche shovels and a probe that is carried out by the tour participants themselves offers the best chance of survival for an avalanche victim. When third party help has to be called to the scene it usually arrives too late! Pay attention to the avalanche report and select safe routes. Always take the avalanche transceiver S1 with you together with the necessary **ORTOVOX SAFETY PRODUCTS** such as an avalanche shovel and a probe. Read the S1 operating instructions carefully and practice both the handling of your avalanche transceiver S1 and avalanche search procedures.

Information on ORTOVOX products and safety notices can be found on the ORTOVOX website at **[www.ortovox.com](http://www.ortovox.com)**

Contact us by e-mail at **[ortovox@ortovox.com](mailto:ortovox@ortovox.com)**

ORTOVOX wishes you wonderful, safe tours!

## CONTENT

Operating elements	01
Technical data	32
EU Declaration of Conformity	32
<b>QUICK REFERENCE</b>	<b>33</b>
Coarse search, refining location and pinpoint location	
Emergency equipment	38
Extended operating instructions	39
<b>MENU</b>	<b>40</b>
Daily function test	43
Locating several avalanche victims	45
Acoustic emergency reception	50
Interference	52
Battery change	53
Protective case and wrist strap	53
Guarantee / service	54
Index of key words	56
Service addresses	144

**[www.ortovox.com](http://www.ortovox.com)**  
Current avalanche warning service information!

## TECHNICAL DATA

**DEVICE DESIGNATION:** ORTOVOX S1

**FUNCTION:** digital with acoustic emergency operation

**CASING:** ergonomic, waterproof, impact-resistant

**DIMENSIONS:** 120 x 80 x 30 mm (closed);

**FREQUENCY** 215 x 80 x 30 mm (open)

**Transmitting:** 457 kHz +80 Hz

The S1 can receive signals from any standard avalanche transceiver with no limitations

**DIGITAL RECEPTION RANGE:** up to 60 m

**SEARCH STRIP WIDTH:** up to 50 m

**TEMPERATURE RANGE:** -20° C to +45° C

IF THE TRANSCIVER GETS WET, DO NOT USE DIRECT HEAT, I.E. SUCH AS A HAIR DRYER; TO DRY IT OUT. HEAT APPLIED IN SUCH A DIRECT MANNER MAY PERMANENTLY DAMAGE THE DEVICE BEYOND REPAIR.

**POWER SUPPLY:**

3 alkaline AAA Mignon 1.5 V LR 03 batteries

**OPERATING TIME**

**TRANSMITTING:** about 250 hours

**RECEIVING:** about 15 hours

**WEIGHT:** approximately 245 g incl. batteries,  
carrying case approximately 120g

**SELECTABLE; ADDITIONAL FUNCTIONS**

- Infrared interface
- Compass
- Inclinator: 0 – 60°
- Thermometer: -20° to +45°C

### EU DECLARATION OF CONFORMITY

Manufacturer:

**X-log Elektronik GmbH**

Responsible person:

**Johann Nowotny,**

**Bahnhofstr. 95,**

**D-82166 Gräfelfing**

declares that the product:

Type: **ORTOVOX**

Model: **S1**

Intended Purpose:

**Searching for avalanche victims**

when used as intended satisfies the basic requirements in accordance with Article 3 of the R&TTE guidelines, Directive 1999/5/EC, and that the following standards have been applied:

**1. Health**

(Article 3.1.a of the R&TTE guidelines)

ETS 300 718 issue: 05/01

**2. Safety**

(Article 3.1.a of the R&TTE guidelines)

ETS 300 718 issue: 05/01

**3. Electromagnetic compatibility**

(Article 3.1.b of the R&TTE guidelines)

ETSI EN 300 718-1

issue: 05/01

**4. Efficient use of the radio**

**frequency spectrum**

(Article 3.2 of the R&TTE guidelines)

ETSI EN 300 718-2

issue: 05/01

**5. Electromagnetic compatibility**

**and radio spectrum matters**

(Article 3.3.e of the R&TTE

guidelines)

ETSI EN 300 718-3

issue 2004/02

**Gräfelfing, 09/07/2008**

(City/date of the Declaration of Conformity)

**p. p. Andrea Reintges**

(name)

The ORTOVOX S1 surpasses the high requirements of European standard EN 300 718.

### INFORMATION FOR THE USER:

Changes or modifications to this device not approved by ORTOVOX can void the users authority to operate the equipment.

FCC ID KF50RTOVOXS1

This device complies with Part 15 of the FCC Rules. Operation is subject to the following two conditions:

(1) the device may not cause harmful interference and (2) the device must accept any interference received, including interference that may cause undesired operation. This equipment has been tested and found to comply with the limits for an intentional radiator pursuant to part 15 of the FCC Rules. These limits are designed to provide reasonable protection against harmful interference in a residential installation. This equipment generates, uses, and can radiate radio frequency energy and if not installed and used in accordance with the instructions may cause harmful interference to radio communications. However, there is no guarantee that interference will not occur in a particular installation. If this equipment does cause harmful interference to radio or television reception, which can be determined by turning the equipment off and on, the user is encouraged to try to correct the interference by one or more of the following measures:

- Reorient or relocate the receiving antenna.
- Increase the separation between the equipment and receiver.
- Connect the equipment into an outlet on a circuit different from that to which the receiver is connected.
- Consult the dealer or an experienced radio/TV technician for help.

**QUICK REFERENCE** FOR THE ORTOVOX S1 AVALANCHE TRANSCIEVER**WEARING THE PROTECTIVE CASE**

Hold the shoulder strap on the protective case by the silver-coloured application and place this over your head and shoulder. Pull the free end of the strap around your back and connect to the case using the snap buckle.

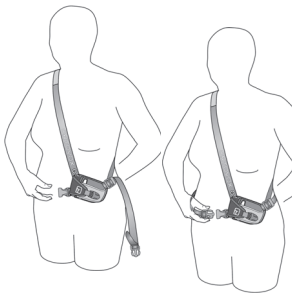
**SWITCH ON AND OFF****SWITCH ON**

Turn ON/OFF switch (1) clockwise 90°.

The transmission monitoring lights (6)

are now flashing. When the battery capacity is between 99 and 75%, 3 short acoustic signals are emitted; between 74 and 50% battery capacity, 2 short acoustic signals are emitted; between 49 and 25% battery capacity, 1 short acoustic signal is emitted and if the battery capacity is less than 25%, a continuous alarm signal is emitted. If the equipment self-test was not able to be completed positively, a warning signal is emitted at regular intervals.

**SWITCH OFF**

Turn ON/OFF switch counter clockwise 90°.



## TO OPEN

Take the S1 from its protective case, press the release button (5) on the left side and then open the S1 unit.

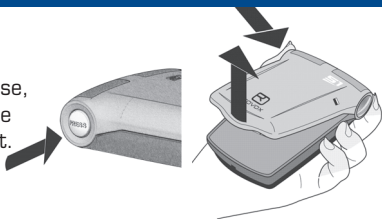

## TRANSCIVER SELF-TEST AND TRANSMISSION MODE

When the device is opened up, once the S1 has been switched ON the transceiver self-test can be watched on the display. Symbols for transmission, reseption, additional functions and battery capacity are confirmed with ticks. The sensors on the S1 for measuring temperature, slope and the earth's magnetism are calibrated.

Close S1 after a positive transceiver self-test. This switches the S1 to transmission mode.

***If an error function or fault is detected, the warning triangle appears.***

The S1 will now transmit and the transmission indication lights on the side (6) will flash.

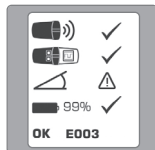
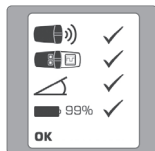

## RECEIVE = SEARCH

Press the release button (5) on the left side of the beacon and open the S1. The search situation will be displayed automatically on the screen (7).

***ORTOVOX recommends switching off mobile phones and radio equipment when locating!***

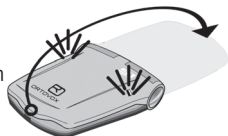

**COARSE SEARCH:**

*Hold the S1 in a horizontal (flat) position during the search!*

If there is no transmission signal being received then the screen will automatically display instructions to carry out a coarse search. Search the avalanche track in search strips of 50 m!

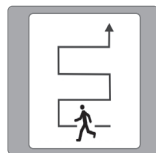
**REFINING LOCATION:**

At approximately 60 m distance from the victim the victim symbol will appear on the display screen (7) with the digital measurement (i.e 55).

The searcher aims the vertical line to the middle of the victim symbol and then moves towards the victim. The acoustic signal from the loudspeaker will sound faster as the distance reduces and thus confirm the measurement result.

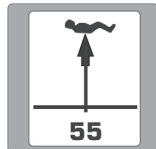
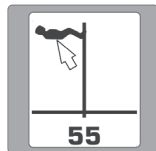

If the S1 again has to determine the initial signal, the instruction to pivot the S1 appears on the display.

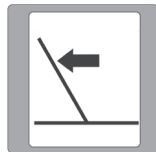
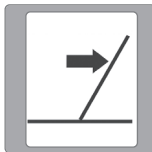

The distance to the victim is now 20 m. Two further victims are shown at distances of 25 m and 30 m by a small icon. The nearest victim (large icon) at a distance of about 20 m remains targeted. When there are several people searching, each of the signals displayed can be targeted and simultaneously located by the other searchers.

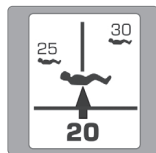

## PINPOINT LOCATION WITH TENDENCY INDICATION:

The patented circular illustration with tendency indication on the S1 makes pinpoint location considerably easier, faster, and more precise.

The process of pinpoint location begins automatically at a distance of 3m. The searcher is approaching the victim: the arrows show towards the center of the circle (tendency indication). The closer he comes to the victim the faster the acoustic signal sounds.



***Hold the S1 steady in front of you.  
Do not turn the S1 during pinpoint location!***

The searcher is approaching the victim: the distance is 2m, the circle becomes smaller and the arrows are pointing to the center of the circle.

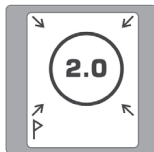

The searcher is moving away from the victim. The circle becomes larger, the arrows are pointing outwards as the distance increases.

The previously achieved, closer position is stored and is referenced by the inner, lighter circle shown on the screen.



The searcher is once again approaching the victim. The circle is becoming smaller, the arrows are pointing to the center and the distance to the victim is reducing.

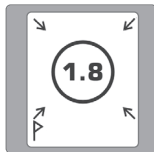

The victim has been located at a depth of 0.3 m. No smaller numbers and no smaller circles are visible.



To mark the located person, the "OK-button" (2) is pressed **once**. The marking flag appears in the display where the located person is buried.



### Cancelling marking

The marking of the last person located can be cancelled by pressing the "OK-button" (2) again. A new pinpointing can be started immediately.

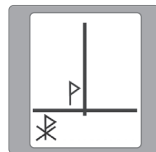

If a second (third) victim is within a 3 m radius, the signal first found cannot be cancelled. In this case the pinpoint location of other victims continues in a consecutive manner as circle icons appear giving their specific respective distances, should the situation arise.

If the victim is shown behind where you are standing, then change direction by 180°, home in on the victim again and walk towards the victim.



You should check the **EMERGENCY EQUIPMENT** on the day before the tour to ensure that it is complete and functional (e.g. avalanche transceivers).

*Average time needed to free a person from a snow depth of approximately 1m:*



Avalanche transceiver, probe + shovel 11 minutes 
Avalanche transceiver + shovel 25 minutes 
Only avalanche transceiver, hands, ski, snowboard 1-2 hours 

Illustration: Dominique Stumpert

*The illustration shows the effect of useful equipment in rescuing an avalanche victim from a depth of 1m.*

#### EVERY MEMBER OF THE GROUP SHOULD HAVE THE FOLLOWING BASIC EQUIPMENT:

##### **Avalanche transceiver**

Mere possession of an avalanche transceiver does not suffice. Each member of the group must be familiar with his device and practise with it regularly. (See [www.ortovox.com](http://www.ortovox.com) for practice opportunities).

##### **Avalanche shovel**

Rescuing avalanche victims is only possible with a shovel.

##### **Avalanche probe**

A probe is required for fastest possible precise location with the pinpoint search procedure.

##### **First-aid kit**

For administration of first-aid to the injured

##### **Bivouac sack**

Protects against hypothermia and can be used as a transport aid.

Supplemental equipment for added safety

Mobile phone for organizing professional help

**Each member of the group has an avalanche transceiver on their person and a shovel and probe in the backpack.**

Decision-making strategies are necessary when planning a tour.

For more information contact the avalanche warning services and Alpine organisations in your country.



## EXTENDED OPERATING INSTRUCTIONS FOR THE AVALANCHE TRANSCIEVER ORTOVOX S1

### TRANSMISSION AND AUTOMATIC SAFETY SWITCHBACK FOR TRANSMIT (MOTION SENSOR):

If the S1 is motionless for 90 seconds while open then the transmission mode will be automatically activated from every function depending on the setting selected. In the event of a subsequent avalanche the S1 switches to transmission after 90 seconds (factory setting; time can be set at 30, 60 and 120 seconds via the "settings" menu).

### COURSE SEARCH (= search for first signal):

Move through the presumed search area in strips with a width of 50 m while ensuring 25 m distance from the side edge of the avalanche.

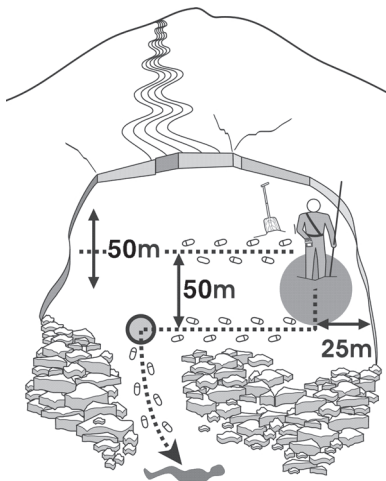

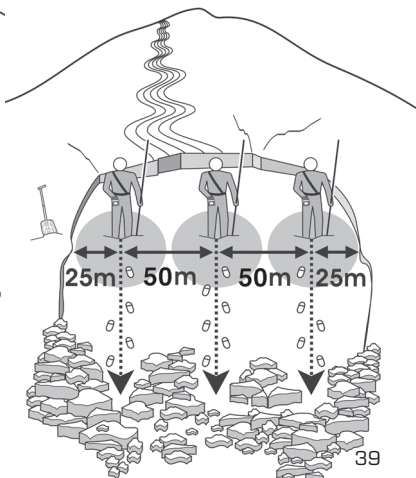

### Several searchers:

The distance between searchers is 50 m.



## MENU

- Accessing the menu: Press 
- Select function: Press  several times
- Confirm function: Press 



Search



Search for more than 3 victims



Compass



Temperature and inclination



Quick test with limited range (approx. 5 m)



Acoustic search



Settings

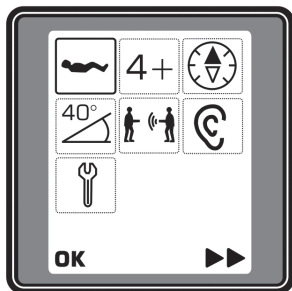



## STATUS DISPLAY

If the S1 detects 4 or more victims (=multiple burials), the "4+" icon appears on the status line of the display



**4+** The searcher is requested to select the function from the menu.

 Warning in case of low battery

 Warning in case of fault

 Warning: Automatic transmission switch over is switched off.

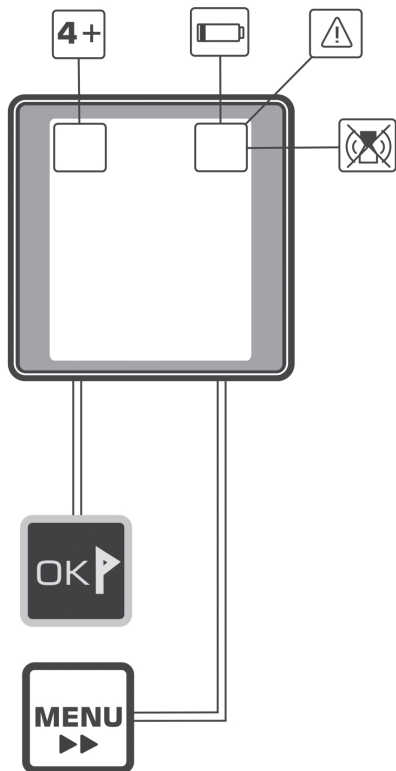

## SOFTKEYS

The keys  and  have several functions. The softkeys show the respective key function:

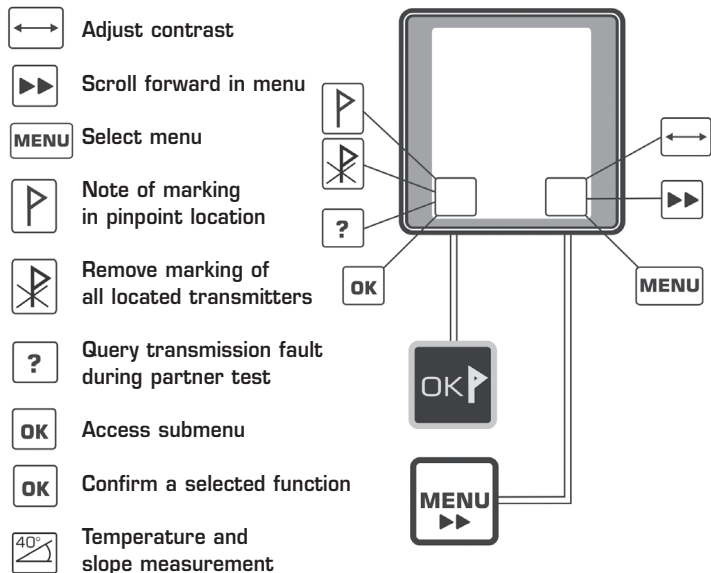

The S1 allows the temperature and the slope angle to be measured. **Measuring the slope:** Lay top cover of the S1 exactly flush with the snow/ski surface.

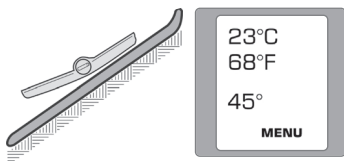

## DAILY FUNCTION TEST BEFORE STARTING A TOUR!

### Checking the receivers:

- All participants set their S1 to 'RECEIVE'.
- A group member (preferably the group leader) sets his/her S1 to 'TRANSMIT'.
- If all group members have acoustic and optical reception then the group members' receivers are working, as is the transmitter of the group leader.
- The group leader now moves away from the group until no group member is still receiving a signal.
- The group members see the increase in distance of the group leader on their displays and can thus test the reception range of their S1.

### Checking the transmitters:

- The group leader opens his S1 (=reception position). The group members close their S1 (transmission position) and pass the group leader's receiver ONE BY ONE at a distance of 20 m.

At the same time, the pinpoint location is tested approaching under 3 m!

## QUICK TEST with limited range (test of the transmitters)

The group leader sets his/her S1 to “transmit test” via menu item  (= limited range).



If the S1 receives an audible (via the loudspeaker) and visible signal (circle with 2 persons) from each individual avalanche transceiver then the transmission function of the units to be tested and the reception function of the group leader are in order.



If a fault turns up on the checked device then the warning triangle appears on the display. The warning triangle signals a serious device fault on the checked device.



Possible faults can be queried by pressing

the  -button (2).

Deviation from the

- Transmission frequency (457 kHz)
- Transmission period
- Period length

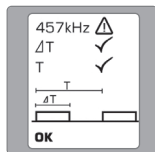

Go back to the short test using the  -button (2).

*If a fault is displayed please send your transceiver directly to your ORTOVOX service office for inspection (see page 144).*

## LOCATING SEVERAL AVALANCHE VICTIMS (SIGNAL SEPARATION):

The S1 separates the signals automatically.

Once the pinpoint location of the first victim is finished, this signal can be marked by pressing the "OK-button" (2). Instead of the victim symbol, a flag now appears where the victim is buried. At the same time the symbol for the next nearest victim is enlarged.

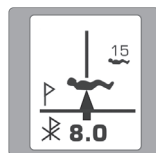

This marking can be cancelled by pressing the "OK" button (2) to check the pinpoint location again if necessary. (This is not possible if several victims are transmitting within a 3 m radius.)

It is necessary to have a short pause between the signals. It may take slightly longer to be able to separate three or more signals due to signal overlap. The receiver needs adequate time to differentiate between each additional transmitted signal. Thus it is practically impossible to separate more than 3-4 signals within a reasonable time and to show them on the display. The S1 therefore automatically reduces its range until the number of signals has been reduced to a quantity that can be displayed in a reasonable time.

---

### **Important notes regarding signal separation:**

*Thank you for purchasing the Ortovox S1 employing the most innovative technology amongst today's avalanche beacons. You will find its unique visual representation and the advanced signal separation technology very helpful while searching for one or even more buried persons. Nonetheless, we want to draw your attention to some important aspects of search, especially in multiple-burial scenarios, and their physical background:*

*In real avalanche accidents, frequently two or more persons are buried with their beacons transmitting at the same time. Sometimes, and unpredictably, two or even*

more beacons are transmitting their impulses exactly simultaneously for a longer period of time. The transmitted signals of two analog beacons with long pulse durations or digital beacons transmitting simultaneously overlap and mix up. Frequently they can no longer be separated for physical reasons. In such an overlap state, a single transmitter's signal cannot be measured, neither using analog nor digital technology. Unfortunately, such an overlap state can continue for 30 or more seconds in some cases. It is necessary to wait until two overlapping impulses are drifting apart. Using the Ortovox S1, you can solve this physically determined problem applying the following three search strategies:

1. Switch to the 4+-Mode and use micro search stripes with a width of at most 5 m or 16 ft (cf. p.47)
2. Use the Ortovox sector search strategy (cf. p.49). You can combine this strategy with the 4+-mode.
3. Switch to the acoustic search mode (cf. p.50)

*Advice: If the number of buried persons is not known or unsure, for safety reasons it is required to use one of the aforementioned methods to detect and locate potential further buried persons. For detailed information please visit our website at [www.ortovox.com](http://www.ortovox.com)*

### Select "4+" mode to locate more than 3 transmitters

Access the menu with the  key and select the function 

When several transmission signals interfere with one another, a location procedure is not possible. Therefore the stop sign appears for a few seconds. Wait until stop hand disappears and then continue to locate!

When there are more than 3 to 4 transmission signals, you will see "4+" top left. Access this function with the "menu" button (3).

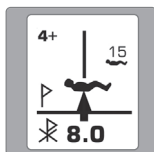
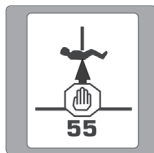



After confirmation, the reception sensitivity on the S1 is continually limited to 5 m. Consequently the search strips should be reduced to a width of 5 m. The restriction to a 5 m search strip width is shown by two black bars on the side of the display.

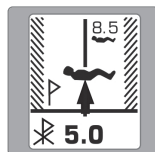

**There are three methods available for locating victims:**

- micro-search stripes
- 3 circle method
- ORTOVOX sector method

## MICRO-SEARCH-STRIPS

Once the 1st victim has been located and rescued by helpers, the search stripes have to be set at 5 m intervals. The avalanche area is searched for victims in this way. The S1 now scans circular areas with a diameter of max. 10 m and every victim in this circle is shown.

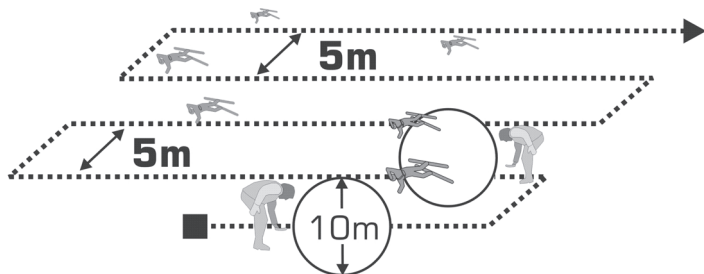

### 3 CIRCLE METHOD

- After locating the first victim, helpers rescue the person.
- To find additional signals the searcher moves in successive circles with radii of 3, 6, and 9 meters respectively. The center of each circle is the point where the first victim was found. In this process the searcher must pay close attention to the display.
- When the searcher receives no further signals in the smallest circle, he moves to the next circle.
- Important: Walk the circle completely!

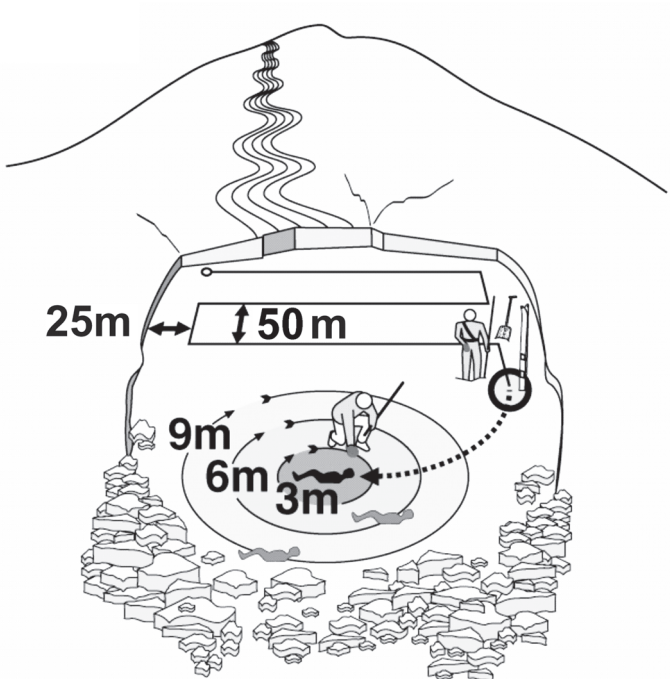

## ORTOVOX-SECTOR-METHOD

1st sector: Once the 1st victim has been located and rescued by helpers the surrounding area is searched by sectors.

2nd sector: approaching from left.

3rd sector: approaching from right.

4th sector: approaching from underneath.

Before each approach in a new sector, the “4+ mode” must be restarted via the menu.

### Caution:

*It is, of course, possible to get a bearing on signals that have already been located. The searcher should then concentrate on signals that have not yet been marked in the avalanche area.*

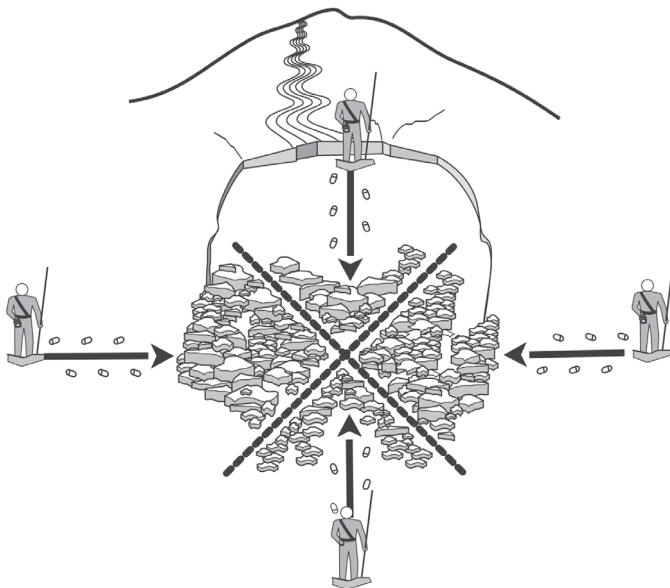

## ACOUSTIC EMERGENCY RECEPTION (SAFETY SETTING)

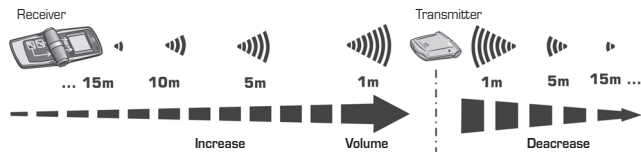

The ORTOVOX emergency safety setting allows an acoustic search when battery capacity is low. Use this function like a basic acoustic analog beacon. If batteries have been allowed to run too low (remaining capacity less than 25%) the microprocessor and the display will switch off automatically to conserve the battery power. Now only acoustic reception is available. Emergency acoustic reception can, however, also be switched on via menu (acoustic search) for practice purposes. Switching off emergency acoustic reception: close the S1 and open it again or hold down both buttons (2 and 3) for 5 seconds. If the battery capacity is very low the S1 is automatically switched to the highest possible reception level for emergency acoustic reception. The 'OK' button is used to reduce the signal. The 'menu' button is used to increase the volume level. After initial reception the loudspeaker will sound the transmission signal. TURN the S1 in order to determine the direction with the strongest reception. Now the searcher will move in this direction for 5 m, reducing the volume if necessary. Then the searcher once again turns the S1 to the direction with the highest volume and again moves 5 m in this direction. The volume increases as the searcher moves closer to the avalanche victim. During the pinpointing phase (= lowest reception level) do not turn or tip the S1. Now mark the point in the longitudinal direction with the loudest signal. A search is also made for the loudest signal to the right and left of this point. The avalanche victim is located at the point with the loudest signal.



## SETTINGS

The following settings can be queried, selected or changed via the menu symbol



- Loudspeaker
- Motion Sensor settings
- Information about device number, software version, receiver function and battery capacity
- Display contrast setting
- Infrared interface for connection to a computer

### Loudspeaker

The loudspeaker function can be set to "loud", "medium" and "off".

### Switch to automatic transmission (Motion Sensor)

If the S1 is not moved within the period of 30, 60, 90 or 120 seconds, then it automatically switches to transmission mode from whatever mode it is in. A short warning signal is emitted 10 seconds before automatically switching. The switch to automatic transmission is pre-set at 90 seconds when delivered. The switch to automatic transmission can also be switched off.

**Attention:** If the switch to automatic transmission is switched off, then the S1 will NOT automatically switch back to transmission mode if someone is buried by a subsequent avalanche!

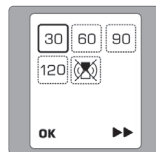
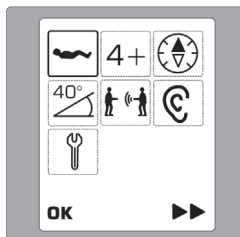

## Information about device number, software version, receiver function and battery capacity

The sub-menu shows

- device number
- software version
- transmitter/receiver function and
- current battery status

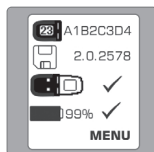

## Display contrast setting

The desired contrast is set using the “menu” button (3) and retained with the “OK” button (2).

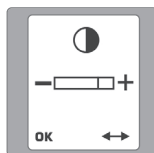

## Infrared interface

The S1 can be connected to a computer via it's infrared sensors and an additional infrared scanner (accessorie) for:

- update/upgrade
- printout and management of transceiver's functions



## INTERFERENCE IN TRANSMITTING AND RECEIVING PERFORMANCE

Interference to the transmission and reception performance can be caused by lightning, lifts and power plants, radio equipment, mobile phones and other electronic equipment. **Mobile phones and radio equipment should be switched off whilst searching.** The minimum distance between two avalanche transceivers and to metal, radio equipment, mobile phones, magnets etc. should be at least 30 cm.

## CHANGING BATTERIES

(when the equipment is switched off)

Remove the screw from the battery compartment on the back of the S1 and remove the batteries from the battery shaft using the strap. Replace three fresh AAA Alkaline batteries 1.5V LR 03 and make sure the positive and negative poles are inserted correctly. Use only brand name batteries. No rechargeable batteries and no lithium batteries.

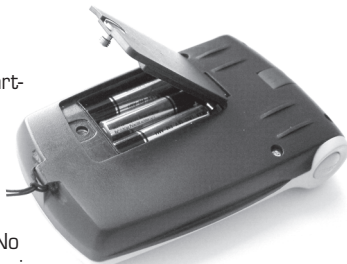

## SEPARATING THE PROTECTIVE CASE FROM THE AVALANCHE TRANSCEIVER AND ATTACHING THE WRIST STRAP

The protective case can be separated from the avalanche transceiver for cleaning purposes. The wrist strap can be attached in place of the protective case.

For safety reasons,  
ORTOVOX only recommends using the supplied  
protective safety case when wearing the beacon!



### IMPORTANT INFORMATION!

Remove the batteries from the avalanche transceiver during the summer months. The ORTOVOX factory guarantee is invalid by damage due to battery leakage. Never use rechargeable batteries (rechargeable batteries such as Ni-Cd cells). Rechargeable batteries have significantly lower operating voltage, and thus lower range and limited service life. In addition defective rechargeable batteries cannot be detected immediately. Once they have been recharged they show full battery voltage, however they can drop off to 0 after extremely short service (life threatening hazard!).

If you delay changing batteries (capacity <25%), the micro-processor, the distance display, and direction display will switch off. In such case, approximately only twenty hours of emergency analog transmit operation and one hour of emergency receive operation are possible.

## STORAGE

After the tour take off the S1 and store it in its switched off status in a well-ventilated dry location. Most often, the well-designed casing prevents condensation for the most part. To ensure that the device will function for several years we recommend a gentle drying of the carrying system and the avalanche transceiver, itself. If your transceiver gets wet, do not use direct heat, i.e. hair dryer, to dry it out. Heat applied in such a direct manner may cause permanent damage. Protect the avalanche transceiver from excessive moisture or excessive heat. Protect the batteries from cold temperatures.

## GUARANTEE

With the purchase of a new ORTOVOX avalanche transceiver and submission of the filled-out guarantee card including a copy of the retailer's invoice (page 54) a full five-year factory guarantee starting from the date of manufacture is provided. The valid guarantee period is shown on the test seal in the battery compartment and on the device packaging. For example, if the symbols IV/11 are written on the test seal, it means that the factory guarantee will expire at the end of the 4th quarter 2011.

Also, the seal is a reminder of the time period during which the recommended device inspection is free of charge. Within the guarantee period, faulty parts will be repaired or replaced at no cost. The exceptions are damage due to improper handling and normal wear and tear. The ORTOVOX factory guarantee is invalid if there is damage due to battery leakage. Any further performance guarantees and subsequent damages are expressly excluded. Guarantee services performed neither cause the guarantee period to be extended or restarted.





## SERVICE

The ORTOVOX S1 is a rescue device. Its perfect operation might be crucial for life. To ensure your unit is functioning properly, send the device for factory inspection according to the dates shown on the test seal.

*Please use our inspection service in the summer months, so that your device will be ready for operation when winter starts.*

For repair or factory inspection please send the avalanche transceiver directly to our service center (see page 144).

## IMPORTANT INFORMATION!

Avalanche transceivers are designed to support the assistance offered by companions in the event of avalanche burial! Your presence in areas where avalanche hazards exist is fraught with potential risk; only remain in such areas in the company of experienced participants. Effective use of an avalanche transceiver requires appropriate training and constant practice. Wear your avalanche transceiver close to your body under your outer clothing. ORTOVOX strongly recommends that you carefully read the operating instructions provided with the avalanche transceiver. Always take a shovel and a probe when you go off-piste in areas where avalanche hazards exist, and never tour alone. Give due consideration to worldwide, current Please check the avalanche reports prior to planning your off-piste activities at: [www.ortovox.com](http://www.ortovox.com) Before you travel in an area where an avalanche hazard exists, ensure that all avalanche transceivers are functioning properly and that all batteries are in good operating condition. **The S1 fulfils the highest safety requirements and is characterized by its clear and uniquely simple illustration of the search situation on the graphic display!**

# INDEX

## A

Acoustic emergency reception (Safety setting)	50
Acoustic search	40,50
Automatic transmission switch (motion sensor)	39,51

## B

Battery	32
Battery capacity	34,50
Battery change	53
Button menu	40
Button OK	40

## C

Cicular illustration (patented)	36
Coarse search	35,39
Compass	32,40
Conformity (EU declaration)	32
Current battery status	52

## D

Daily function test receiver	34,43
Daily function test transmitter	34,43
Deviation (from standard)	44
Device number	52
Digital reception range	32
Display contrast setting	52

## E

Emergency equipment	38
Extended operating instructions	39

## F

Frequency	32
-----------	----

## G

Guarantee	54
Guarantee Card	58

## I

Inclinometer	32,40
Infrared-sensors	32,52
Infrared interface	32,52
Interference in transmitting/ receiving	52

## L

Limited receiver sensitivity	45,46
Loudspeaker	51

## M

Marking	37
Marking (cancelling)	37
Menu	40
Multiple victims („4+-Mode“)	45
Micro-search strips	47

<b>O</b>			
Open	34	Settings	40,51
Operating elements	01	Shovel	38
Operating time „transmit“	32	Signal separation	45
Operating time „receive“	32	Signal overlap	45,46
ORTOVOX Sector methode	49	Softkey	42
		Software Version	52
		Standard test (EN Avalanche Transceiver Standard)	44
<b>P</b>		Status display	41
Probe	38	STOP sign	46
Protective case	32,53	Storage	54
Printout and management of functions	52	Switch OFF	33
Pinpoint location (tendency indication)	36	Switch ON	33
		<b>T</b>	
<b>Q</b>		Technical data	32
Quick reference	33	Tendency indication	36
Quick test	40,44	Thermometer	32,40
		Three circle method	48
<b>R</b>		Transmission Indication lights	34
Range	32	Transmission (and automatic safety switchback for transmit)	39
Receive/search	34	Transceiver self test	34
Receiver function	52	<b>U</b>	
Rechargeable battery	53	Update	52
Refining location	35	Upgrade	52
		<b>W</b>	
<b>S</b>		Warning triangle	34,41
Search	35	Wearing protective case	33,53
Search strip width	32,35,39	Weight	32
Sector method	49	Wrist strap	53
Selectable, additional functions	32,40		
Self test	34		
Service	55		
Service Center	144		

# GUARANTEE CARD

Name \_\_\_\_\_

City, State, Zip \_\_\_\_\_

E-mail \_\_\_\_\_

Telephone \_\_\_\_\_

Model **ORTOVOX S1**

Serial number \_\_\_\_\_

(inside of battery compartment lid)

Purchased at \_\_\_\_\_

Address \_\_\_\_\_

City, State \_\_\_\_\_

Please provide below a **detailed** explanation and description of your unit's faulty performance!!!!

In case of service please fill out this card and send it to the responsible ORTOVOX service center (see page 144).

**IMPORTANT!**

Please hold in  
safe keeping



**ORTOVOX**  
www.ortovox.com

